



# NIR

DIBBLING BELT with drills



## MACHINE DESCRIPTION

The NIR drilling unit is particularly suitable to make holes in the soil for transplanting. It can be connected in line to any other machine.

TECHNICAL DATA	M.U.	NIR
HOURLY PRODUCTION (max)	cycles/hour	1800
HOURLY PRODUCTION (15 - 18 pots in the shuttle tray)	trays/hour	600
TRAYS DIMENSIONS (max)	mm	750x500
TRAYS HEIGHT (max)	mm	150
BELT LENGTH	mm	2300
WEIGHT	kg	330
AIR CONSUMPTION (max)	l/min	150
INSTALLED POWER	kW	1
DRILL MOTOR	kW	0,37

## TECHNICAL SPECIFICATIONS

- Control with 4,5" monochromatic touch-screen.
- Tray positioning on belt is controlled by encoder and PLC.
- Head assembled on double linear bearing with pneumatic movement.
- Soil cleaning with blow and discharge with advancement belt.
- Nr. of rows, diameter and drill speed to be defined with our technical department.
- Plate to press the soil guided with springs.
- Depth dibbler easy to adjust with a handle.
- Drill plate on sliding guides for a rapid change.
- Available in left and right version.

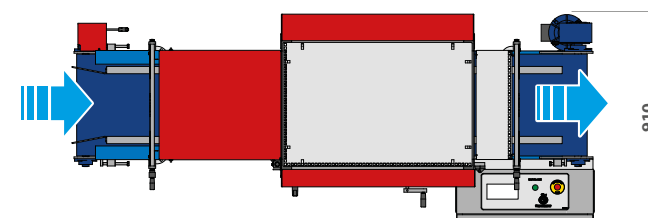
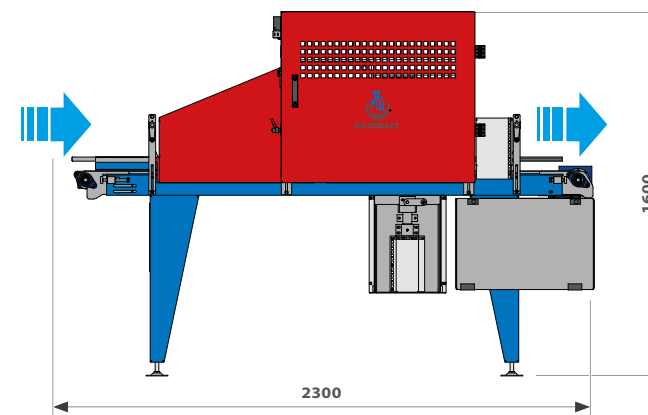

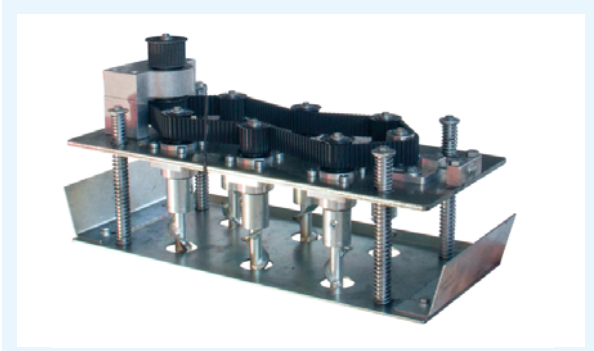

Plate with drills.

- **Plate with drills.**
- **Plate with eccentric pins.**
- **Plate with fix pins**, for seeding or transplanting.
- **Electronic speed variator** for the drills.
- **Soil return belt** to the trayfiller.
- **Wheels for transport** (nr. 2 fixed and nr. 2 turning).



Drills **easily interchangeable**, according to the need.



NIR **connected in line** with a RW transplanter.

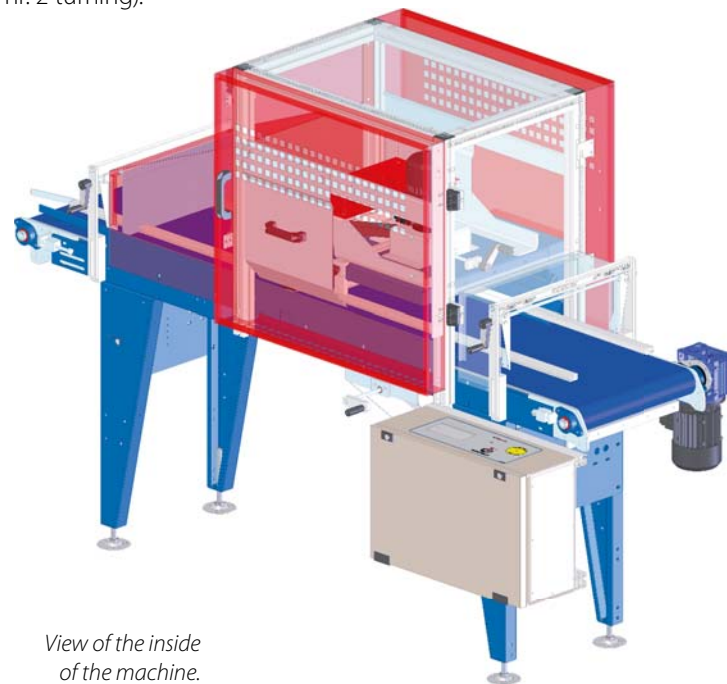

View of the inside of the machine.



Easy and quick **extraction** of the plate.